

Technical data

proMHD14R	
Signal frequency ranges	Forward: 470 .. 862 MHz; return 5 .. 10 MHz
Forward gain	4.5 dB
Return gain	3 dB (active in return-path mode only)
Noise figure, typical and (max.)	2.8 (3.2) dB
Output capability ¹	88 dB μ V
Max. recommended input level ¹	84 dB μ V
Isolation between outputs	\geq 16 dB
Input filter characteristic	\geq 26 dB rejection (relative to passband gain) for all frequencies \leq 400 MHz
DC power requirement	Aerial-amplifier mode: 5 .. 12 V DC at 20 mA ² ; return-path mode 9 V DC at 35 mA ³
Infrared remote receiver power out	8.5 V at 10 mA max. (each output), active in return path mode only, s/c protected
Signal connector type	Type-F (IEC 60169-24)
Operating temperature range	-20 .. +50 °C
EMC standard	BS EN 50083-2: 2001

Notes

1. Signal handling capabilities are given for 5 analogue TV channels plus up to 6 DTT multiplexes at \leq 14 dB relative level.
2. Limiting values 4.8 .. 12.6 V (powered via output, aerial-amplifier mode). Built-in surge protection is provided.
3. Limiting values 8.5 .. 12.6 V (powered via input, return-path mode). Built-in surge protection is provided. Current loading given in table excludes consumption of remote infrared receivers.

2-Year Guarantee

This guarantee covers failure of your PROception product resulting from manufacturing defect within a period of 2 years from the date of supply to the end-user. This guarantee does not cover damage to the product caused by abuse, tampering, defective installation or natural causes such as lightning discharge. Repair or attempted repair, other than by the manufacturer, will render this guarantee void. This guarantee does not affect a consumer's statutory rights.

Performance data given are typical unless otherwise stated. Proception Limited reserves the right to change product designs and specifications without prior notice.

Proception Limited,
177-187 Rutland Road
SHEFFIELD
S3 9PT
United Kingdom

Web: <http://www.proception.co.uk/>
e-mail: support@proception.co.uk

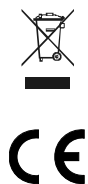

PD2011-9030-02

PROception

proMHD14R
Dual-mode
4-Way Outdoor UHF Amplifier

INSTALLATION INSTRUCTIONS

This unique versatile amplifier is an addition to the PROception range of UHF masthead products. The unit has two modes of operation, allowing it to be used either as a straightforward multi-way 'aerial amplifier' for off-air signal distribution, or as a 'return-path amplifier' for distribution of the UHF loop-through output of a Sky* receiver. In the latter mode full support is provided for remote infrared receivers ('eyes'). The use of 'F' connectors makes the amplifier easy to use with a wide range of cable sizes and helps to ensure good system screening.

Features

- Dual-mode operation – can operate as an aerial amplifier, or as a return-path amplifier with Sky* remote control facilities.
- Flexible powering options: 5 - 12 V in aerial-amplifier mode; 9 V from Sky* receiver in return-path mode.
- Excellent noise figure and output capability.
- Input filtered below 470 MHz to reduce risk of interference problems from CB, private mobile radio, TETRA, etc.
- Suitable for both digital and analogue applications, fully DTT-compatible.

Application guide

See application example diagrams on page 2.

Aerial-amplifier mode: in this mode the proMHD14R functions as a straightforward 4-way UHF masthead amplifier. The input will usually come directly from the UHF antenna. Power (5 - 12 V DC) can be supplied via any of the four outputs, providing flexibility in the location of the power unit. In this mode no power is passed to the other outputs and the return-path amplifier stage is disabled.

Return-path mode: this mode is automatically enabled when the amplifier is powered via its input. Usually the input will be fed directly from the second RF output (RF OUT-2) of a Sky Digibox or Sky+* receiver, which should have its 9 V second outlet powering enabled (see over). In return-path mode power is present at all outputs for powering remote infrared receiver 'eyes,' such as the PROception proSAT1EYE. Infrared receiver power is individually short-circuit protected, so that a DC short at any output will not affect operation of remote control via the other outputs.

The relatively low forward gain of the amplifier (4.5 dB) is sufficient to compensate for additional download cable losses in most systems, whilst avoiding intermodulation and other overload problems which easily result from the use of excessive gain. Where more gain is needed in aerial-amplifier mode (for example in installations with very long cable runs, or in weak signal areas) the proMHD14M or proMHD14V masthead amplifiers should be considered (these alternative products do not provide return-path capability).

* "Sky" and "Sky+" are registered trade marks of British Sky Broadcasting Group PLC.
† "Freeview" is a registered trade mark of the British Broadcasting Corporation.

Fig.1 proMHD14R – aerial amplifier installation showing two (optional) methods for splitting outputs.

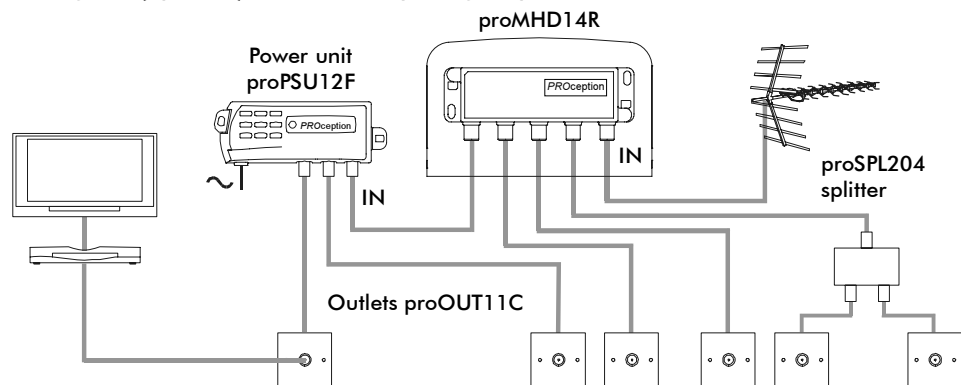
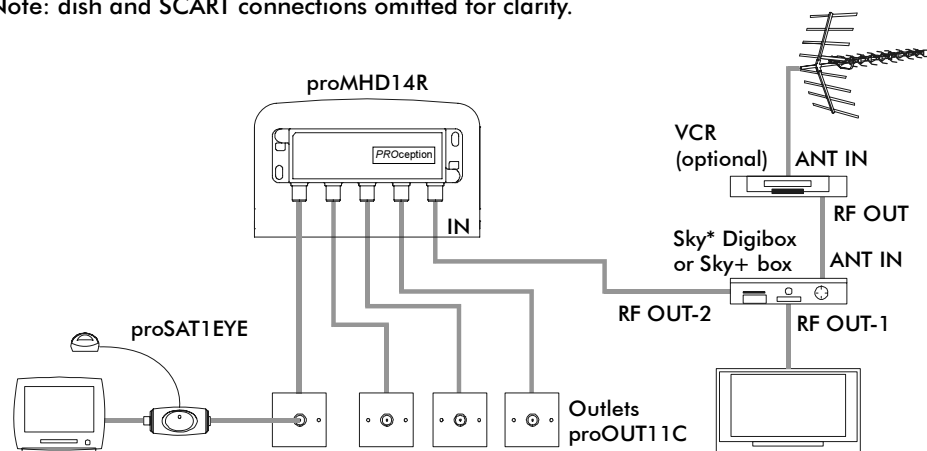

Fig.2 proMHD14R – return path application with Sky* box. Note: dish and SCART connections omitted for clarity.



Powering options

Power for operation in **aerial-amplifier mode** can be supplied by a PROception proPSU11F or proPSU12F 12 V power unit connected in any of the output lines (Fig. 1). The amplifier can also be powered at 5 V from certain DVB-T (Freeview†) receivers which have an option to provide power on their antenna sockets. A separate power unit will not be required if this type of receiver is in use on any of the outputs, provided that it can be left connected continuously to the mains supply.

In **return-path mode** 9 V power is provided to the input of the proMHD14R by the Sky* receiver (Fig. 2). The latter must be configured in its INSTALLER SET-UP menu to provide power on RF OUT-2. On the Sky handset press SERVICES, 4, 0, 1, SELECT, then select the SECOND OUTLET POWER SUPPLY option. Set this to be ON (the default state is OFF), SAVE SETTINGS and BACK UP out of the menus. Sky* receivers can supply sufficient current to power the proMHD14R together with up to four proSAT1EYE infrared receivers.

Fixing

Methods for mounting the amplifier are illustrated in Figures 3 to 5. The cable tie fixing is intended to support the weight of the amplifier only. Cables should be taped to the mast at intervals of approximately 400 mm to ensure that their weight is adequately supported. When used in return-path mode the amplifier will usually be mounted on an outside wall. A high fixing position is recommended to reduce the risk of tampering or vandalism.

Being fully screened, the amplifier will not be affected by proximity to an antenna. However clearance of not less than 300 mm from the nearest part of the antenna should be observed to avoid degrading the antenna's performance. Manufacturer's instructions regarding routing of the cable from the antenna terminal box must be followed if provided.

Fig.3 cable tie fixing

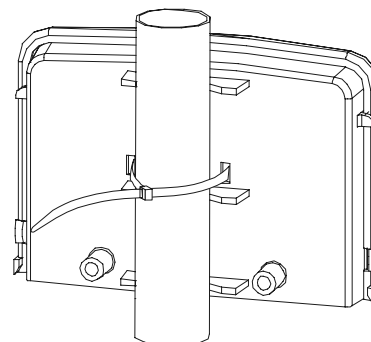

Fig.4 fixing to flat surface

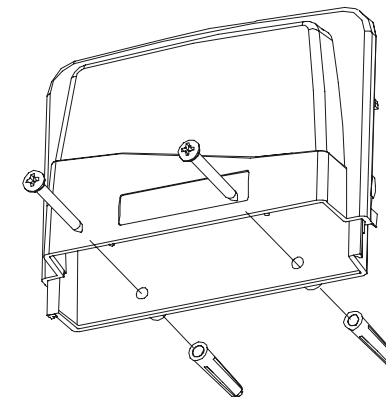
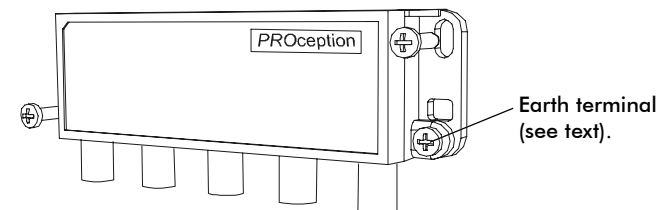

Fig.5 Fixing the amplifier module directly (indoor application only, discard mouldings).



Signal connections

To preserve RF screening integrity the signal connections to the amplifier should be made using good quality coaxial cable and connectors. This is particularly important with DTT to minimise the ingress of impulsive electrical interference. The use of cable 'benchmarked' under the CAI scheme is recommended.

Crimp 'F' connectors, used in accordance with the manufacturer's instructions, will give the best results. The importance of achieving sound braid connections cannot be overstressed. Connectors should be tightened with a spanner, not left finger-tight.

System earth bonding

Earth bonding terminals are provided on the amplifier casting for use where necessary. Distribution systems supplying signals to more than one household should comply with the safety requirements of BS EN 50083-1. This effectively requires the system to be earth bonded. (The use of isolated outlet plates is no longer recommended since they compromise screening integrity and allow ingress of interference.)